

# GO!™

# DMR

Business Digital & Analog 2-Way Radio  
by blackbox™

**3**  
YEAR  
REPLACEMENT  
WARRANTY

**NEW!**

only  
4.5"



- Affordable
- MotoTRBO Tier II & Hytera Compatible
- IP56 Water Resistant
- 32 Channels
- 2,000 mAh Battery
- Motorola M1 Radio Connector
- High & Low Power

**UHF**  
OEM  
GRADE

# USER MANUAL

## **GO!® Quick Start:**

Perform the following steps to assemble your handheld radio:

- Charge the battery.
- Install the battery.
- Install the antenna.
- Install the belt clip.
- Turn on the radio.
- Select a channel.
- Install your audio accessory (if needed).
- Adjust the volume.

### **Charging the Battery**

The radio is powered by a Li-Ion battery. To protect the battery from damage and comply with the warranty conditions, you can use only the charger provided with the battery for charging. To maximize battery performance, it is recommended to charge the battery for 10 to 12 hours before the first use.

### **Installing the Battery**

Align the battery with the battery slot on the rear side of the radio. Push the battery into the slot until it is fastened. Before removing the battery, turn off the radio first. Press the battery fastener, and then remove the battery.

### **Installing the Antenna**

Turn off the radio, place the antenna into the installation hole, and turn the antenna clockwise. To remove the antenna, turn the antenna anticlockwise. Before removing the antenna, ensure that you have turned off the radio and removed the universal interface cover. To replace the antenna, use a specified antenna to replace the old one. Otherwise, your radio may be damaged.

### **Installing the Belt Clip**

Align the screw holes on the belt clip with those on the rear side of the radio, and fasten the belt clip with screws

### **Turning On the radio**

Turn the volume/power knob clockwise until you hear a click sound. The radio gives a short beep sound, indicating that the radio is successfully turned on.

### **Selecting a Channel**

Simply look at the knob with the numbers and rotate until you land onto the group channel you desire. You should also hear the Voice Enunciation through the speaker or earpiece of which channel you are on.

## Installing an Audio Accessory

Remove the protective cover on the side of the radio and plug in your earpiece or headset.

## Adjusting the Volume

Turn the volume knob clockwise to turn up the volume. To turn down the volume, turn the knob anticlockwise. Be careful if you are wearing an audio accessory!

## Radio Control

Please read the following carefully:

- radio control options
- Programmable buttons
- PTT button

## Radio Control Options

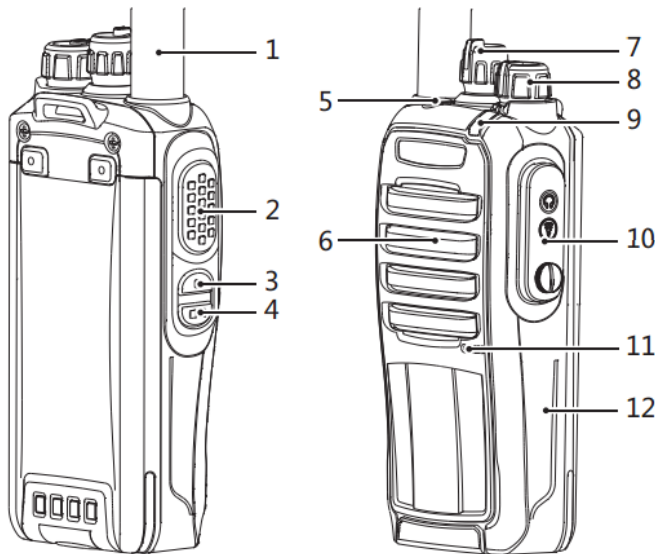

- 2 Slot Simplex
- MotoTRBO Tier II & Hytera Compatible
- IP56 Water Resistant
- 32 Channels
- 2,000 mAh Battery
- Motorola M1 Radio Connector

NO.	Feature
1.	Antenna
2.	PTT button
3.	Side button PF1
4.	Side button PF2
5.	Side button PF3
6.	Speaker
7.	Channel Selector Knob
8.	Power / Volume Knob
9.	LED Indicator
10.	SP/MIC cover
11.	Microphone

### Note:

The button marked with an asterisk means a programmable button.

## **Programmable Buttons**

Your agent can set a programmable button to a shortcut button for a function or channel or call group in accordance with the duration for which the button is pressed:

- Press: means pressing a button and immediately releasing the button.

Note: This radio can't press and hold the buttons to change the function.

## **Assignable radio Functions**

- Emergency call: initiates or cancels an emergency alarm or call.
- Monitoring: monitors any activities in a selected analog channel.
- One-press call: initiates a predefined private call, group call, or short message by pressing one button.
- Scanning: enables or disables scanning.
- VOX: enables or disables the VOX function.
- Zone: changes the current zone of the radio. This radio has 2 groups.
- Power level: switches between transmitting power levels.
- Kill / Stun: Remote to close and forbid the radio.
- Revive: Remote to open and revive the radio.
- Remote Monitor: Remote to monitor the radio
- Talk around: Turn ON / OFF this function.
- Radio check : Check whether the target radio is in the working state.

## **PTT Button**

Each channel can be configured as a digital channel.

- During a call, if you press the PTT button, the radio transmits signals to other radios in the call. Press and hold the PTT button to talk. Release the PTT button to listen to other members in the call. When you press the PTT button, the microphone is activated.
- If there is no existing call, you can press the PTT button to initiate a call (for details, refer to the Initiate a Call section). If the call admission tone function is activated, wait until the short prompt tone ends.
- During a call, if the "idle channel prompt" function is enabled (preprogrammed by your agent), when the target radio (that receives your call) releases the PTT button, you will hear a short prompt tone, indicating that the channel becomes idle, and you can respond.
- If the existing call is interrupted (for example, when you receive an emergency call), you will hear an idle channel prompt tone. You can disable the "idle channel prompt" function by disabling the tone/prompt function (for details, refer to the Enable or Disable the Tone/Prompt Function section).
- To switch between digital channels, turn the knob.

## **Status Indicators**

You can learn about radio operation through the following:

LED indicator.

Prompt tone.

## LED Indicator

The LED indicator indicates operation of the radio.

- If the indicator is lit red, it indicates that the radio is transmitting signals, send messages, encryption calling or data.
- If the indicator is lit green, it indicates that the radio is being turned on, or receiving a call, messages, encryption calling or data.
- If the indicator is lit orange, it indicates the radio is scanning.

### Note:

You can turn ON/OFF the some LED indicator via programmed software: transmitting, receiving, scanning state, switch channel, turn on radio, carrier wave, call hang up.

## Prompt Tone

Prompt tones can help you learn about the radio status or response to data receiving.

- Digital mode private call prompt tone: Press PTT, radio gives a “di” tone.
- Digital mode group call prompt tone: Press PTT, radio gives a “di” tone.
- Analog mode call prompt tone: Press PTT, radio doesn’t give a “di” tone.
- Call roger prompt tone: Radio gives a “du” tone.
- Keypad prompt tone: Radio gives a “di” tone.
- Turn on radio prompt tone: Radio gives a continues tones.
- Switch channel prompt tone: Radio gives two “den” tones.
- Forbid transmitting prompt tone: Radio gives “den” tones continuously, until user release the PTT to stop transmitting.
- Low battery prompt tone: Radio gives low battery tones continuously. You can program the time via software.

## Receive and Initiate a Call

You can use your Radio after learning how to configure the Radio.

Get familiar with the basic call function as follows:

Select a zone...

Select a channel, a user ID, or a call group ID...

Receive and respond to a call...

Initiate a call...

## Select a Zone

A zone defines a channel group. The Radio supports a maximum of two zones, and each zone supports a maximum of 16 channels.

Perform the following steps:

1. Press the pre-programmed zone button.
2. If you see the LED indicator flash green, it indicates that the Radio is local the zone 1. If you see the LED indicator flash red, it indicates that the Radio is local zone 2. Same time, Radio dial speak the local zone NO.

## Select a Channel, a User ID, or a Call Group ID

After selecting a zone (if there are multiple zones), you can turn the channel selection knob to select a channel, a user ID, or a call group ID.

## Receive and Respond to a Call

After selecting a channel, a user ID, or a call group ID, you can receive or respond to a call.

When the Radio is transmitting signals, the LED indicator is lit red. When the Radio is receiving signals, the LED indicator is lit green.

## Receive and Respond to a Group Call

To receive a call from a user group, you must configure the call group on the Radio.

1. When Radio receives the call, the LED indicator is lit green.
2. Hold the Radio vertically, and keep it about 1 to 2 inches (2.5 to 5.0 cm) away from your mouth. Press the PTT button to respond to the call. The LED indicator is lit red.
3. Release the PTT button to listen to other members in the call.
4. If no one talks within a specified period, the call ends.

## Receive and Respond to a Private Call

A private call means a call that a single Radio initiates to another Radio.

When you receive a private call, perform the following steps:

1. When Radio receives the call, the LED indicator is lit green.
2. Hold the Radio vertically, and keep it about 1 to 2 inches (2.5 to 5.0 cm) away from your mouth. Press the PTT button to respond to the call. The LED indicator is lit red.
3. Release the PTT button to listen to other members in the call.
4. If no one talks within a specified period, the call ends.

## Receive a General Call

A general call means a call that a single Radio initiates to all the Radios on the same channel. A general call is used to issue an important announcement.

When you receive a general call, perform the following step:

1. When Radio receives the call, Radio gives a prompt tone ( If you activity this tones), and the LED indicator is lit green.
2. If no one talks within a specified period, the call ends.

### Note:

1. You can't reply a general call.
2. When you receive a general call, if you switch to another channel, the Radio stops receiving the general call. During a general call, you cannot use any programmable button until the call ends.

## Initiate a Call

You can use either of the following buttons to select a channel, a user ID, or a call group ID:

- Channel selection knob
- Pre-programmed button for a one-press call

### Note:

Radio has to activate the Encryption function on the channel, or else Radio can't transmit the Encryption data. Only matching encryption/ decryption devices will function.

## **Initiate a Call with the Channel Selection Knob**

### **Initiate a Group Call**

To initiate a group call, you must join a call group on the Radio. Perform the following steps:

1. Turn the channel selection knob, and use an activated call group ID for selecting a channel.
2. Hold the Radio vertically, and keep it about 2-6 inches away from your mouth.
3. Press the PTT button to initiate a call. The LED indicator is lit red. Then speak into the microphone.
4. Release the PTT button to listen. When a target Radio responds, the LED indicator lights green.
5. If no one talks within a specified period, the call ends.

### **Initiate a Private Call**

Perform the following steps:

1. Turn the channel selection knob, and use an activated user ID for selecting a channel.
2. Hold the Radio vertically, and keep it about 1 to 2 inches (2.5 to 5.0 cm) away from your mouth.
3. Press the PTT button to initiate a call. The LED indicator is lit red. Then speak to the microphone.
4. Release the PTT button to listen. When the target Radio responds, the LED indicator is lit green.
6. If no one talks within a specified period, the call ends.

### **Initiate a General Call**

This function enables you to transmit signals to all the users on the same channel. You must enable this function on your Radio before using this function.

Perform the following steps:

1. Turn the channel selection knob, and use an activated general call group ID for selecting a channel.
2. Hold the Radio vertically, and keep it about 1 to 2 inches (2.5 to 5.0 cm) away from your mouth.
3. Press the PTT button to initiate a call. The LED indicator is lit red. Then speak to the microphone.

#### **Note:**

Other users receiving the general call cannot respond to the call.

### **Initiate a One-Press Group Call or Private Call**

The one-press call function enables you to call a predefined group ID or user ID by pressing one button. This function can be assigned to a press operation you can assign only one ID to one programmable button. There are multiple programmable buttons for the one-press call function. Perform the following steps:

1. Press a pre-programmed button to call a predefined group ID or user ID.
2. Hold the Radio vertically, and keep it about 1 to 2 inches (2.5 to 5.0 cm) away from your mouth.
3. Press the PTT button to initiate a call. The LED indicator is lit red. Then speak to the microphone.
4. Release the PTT button to listen. When a target Radio in the call responds, the LED indicator is lit green.
5. If no one talks within a specified period, the call ends.

When a private call ends, you will hear a short prompt tone.

## **Advanced Functions**

You can use the following advanced functions:

TDMA DMO 2 time slots

Scan list...

Scanning...

SMS...

Set the power level

VOX

Talk around

Remote monitor

Remote alarm

Remote kill

### **TDMA DMO (Direct mode operation) 2 times slots**

DMO 2 times slots will make one frequency point which can be used for two channels at the same time. It will save the frequency resources.

### **Scan List**

You can create a scan list and assign it to a single channel or call group. The radio scans the channel or call group queue in the list on a cycle basis to check whether someone is speaking on the current channel. The Radio supports a maximum of 3 scan lists, and each list supports a maximum of 16 members.

### **Scanning**

When you start scanning, the Radio scans the pre-programmed scan list on a cycle basis to check whether someone is speaking on the current channel. The LED indicator is flashing red.

### **Scanning modes**

Automatic scanning (automatically): When you select a channel or call group for which automatic scanning is enabled, the Radio automatically starts scanning.

### **Start and Stop Scanning**

Perform the following steps:

1. Press the pre-programmed scan button. Or turn the channel selection knob to select a channel for which automatic scanning is enabled.
2. When scanning is started, the LED indicator is flashing orange. When scanning is stopped, the LED indicator is not lit.



### **When the Radio detects an active channel**

The Radio stops at the detected active channel or call group. The Radio stays on this channel for a pre-programmed duration call "idle time".

Perform the following steps:

1. Within idle time, hold the Radio vertically, and keep it about 1 to 2 inches (2.5 to 5.0 cm) away from your mouth. Press the PTT button within the idle time. The LED indicator is lit red..
2. Release the PTT button to listen.
3. If you do not respond within the idle time, the Radio continues to scan other channels or call groups.

### **Send a Predefined Short Message**

You can use a pre-programmed button to send a short message predefined by your agent. This Radio can pre-programmed maximum of 5 messages.

Perform the following steps:

1. Press a pre-programmed button to send a predefined short message to a predefined ID.
2. The LED indicator is lit red.
3. If the Radio gives two chirps, it indicates that the message is successfully sent. If the Radio gives a low-pitch prompt tone, it indicates that the message fails to be sent.

### **Set the Power Level**

You can set the power level for each channel.

If a high power level is set, the Radio can communicate with Radios at a far distance. If a low power level is set, the Radio can communicate only with Radios at a close distance.

Perform the following steps:

1. Press the pre-programmed power level button.
2. If you just hear a "di" prompt tone, it indicates that the Radio operates at a high power level. If you hear two "di" prompt tone, it indicates that the Radio operates at a low power level.

### **Enable or Disable the VOX Function**

This function enables you to initiate a hands-free call. The Radio automatically transmits signals within the specified period, regardless of when the microphone with the VOX function detects voice.

#### **Note:**

The following operations are limited to the Radios on which the VOX function is activated. For details, contact your agent or system administrator.

Perform the following steps:

1. Press pre-programmable VOX button to enable or disable the VOX function.
2. Speak to the microphone clearly.

### **Talk around**

When the repeater don't work, or without the communication range of repeater, but within the communication range of other Radios, you can activate this function to communication with other Radios.

Perform the following steps:

Press pre-programmable talk around button to switch the mode between repeater and talk around.

Frequency	400~470MHz
Channel Capacity	32
Normal Operating Voltage	7.4V
Operating Temperature	-25℃ ~ + 60℃
Store Temperature	-40℃ ~ + 85℃
Weight	9.5 oz          With Standard Li-ion battery
Dimensions :H x W x D(mm)	113.5 X 54 X 33.5 With Standard Li-ion battery
Dust-protection and water resistant	IP56
Battery Life in 5/5/90 Operating Mode 2,000 mAh Standard Li-ion battery	Analog: 14 hrs    Digital: 18 hrs

## Receiver

Frequency	400~470MHz
Channel Spacing	12.5KHz/25KHz
Frequency Stability	+/- 1.5ppm
Analog Sensitivity	0.28uV/-116dBm(20 dB SINAD) 0.22uV/-120dBm(Type)
Digital Sensitivity	0.28uV/-117.4dBm (BER 5%) 0.5uV/-110dBm (BER 1%)
Intermodulation	TIA603C: 60dB    ETSI: 60dB
Adjacent Channel Selectivity	TIA603C: 60dB@12.5KHz ETSI:        60dB@12.5KHz
Co-Channel rejection	12dB@12.5KHz
Spurious Response rejection	TIA603C: 65dB    ETSI: 65dB
Conducted spurious emission	-57dBm@ < 1GHz, -47dBm @> 1GHz
Blocking	84dB
Rated Audio Power	1W
Audio Response	+1dB ~ -3dB
Rated Audio Distortion	3% (Type)

## Transmitter

Frequency	400~470MHz
Channel Spacing	12.5KHz/25KHz
Frequency Stability	+/- 1.5ppm
Power	Low Power: 1W, High Power: 4W
Hum and Noise	-40dB@12.5KHz
Conducted, radiated spurious emission	-36dBm@<1GHz, -30dBm@>1GHz
Adjacent Channel Power	-60dB@12.5KHz
Adjacent Transient Channel Power	-50dB@12.5KHz
FM Modulation Mode	12.5KHz: 11K0F3E
4FSK Digital Mode	12.5KHz (data only): 7K60FXD 12.5KHz (data + voice): 7K60FXE
Modulation Maximum Deviation	2.5KHz@12.5KHz
Nonactive Slot Power	-57dB
Audio Response	+1dB ~ -3dB
Audio Distortion	3% (Type)
Digital Protocol	ETSI TS 102 361-1, -2, -3
Vocoder Type	AMBE + 2™